

# Stratomaster Smart Single

## MAP-1

### Universal pressure monitor



The MAP-1 is a 2.25" instrument which can measure pressures in the range from 0.25 bars (3.6 PSI) to 2.5 bars (36.2 PSI).

Pressure can be displayed in units of millibar, bar, PSI, Kg/cm<sup>2</sup>, inches of Mercury, millimeters of Mercury, kilopascal (KPA) or atmospheres.

The pressure display is also available in form of a bargraph with user selectable sensitivity.

The MAP-1 is primarily intended as manifold pressure gauge, however, due to the universal nature of this accurate instrument it can be used for many other applications as well.

Typical applications:

Engine manifold pressure, Turbo boost pressure, Barometer, fuel or oil pressure gauge (with additional isolation kit), pressure reference, airfoil research and testing.

## The main display and function buttons

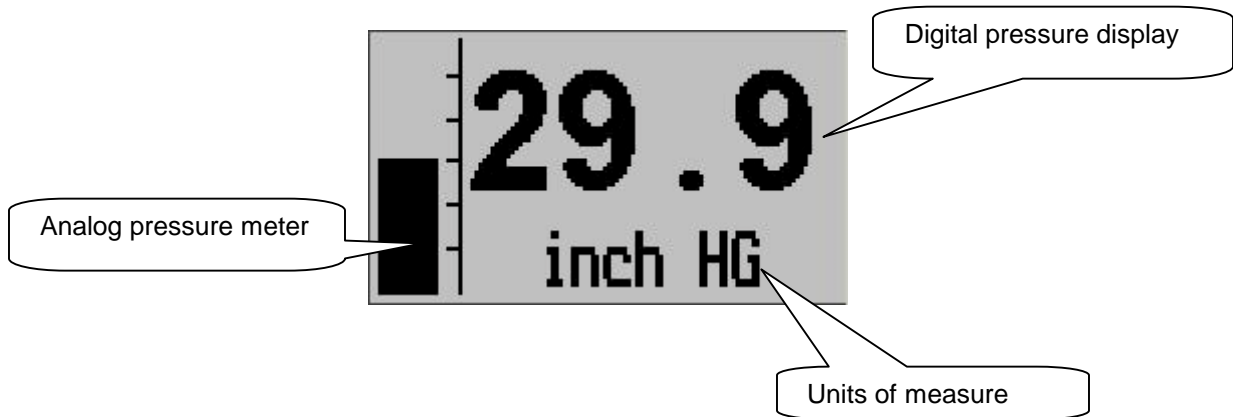

## Setting up the GF-1

Press the Menu key to enter the menu. You can move forward and backwards in the menu by using the + and – keys. To change or select a menu item, move the highlight to the desired item and then press the Menu key. To end an edit or function, press the Menu key again.

To exit the menu and continue normal operation, select the **\*\*\*Done\*\*\*** function and press the Menu key. Note, all changes you have initiated during your session will only be remembered by the instrument if you exit the menu using the **\*\*\*Done\*\*\*** function.

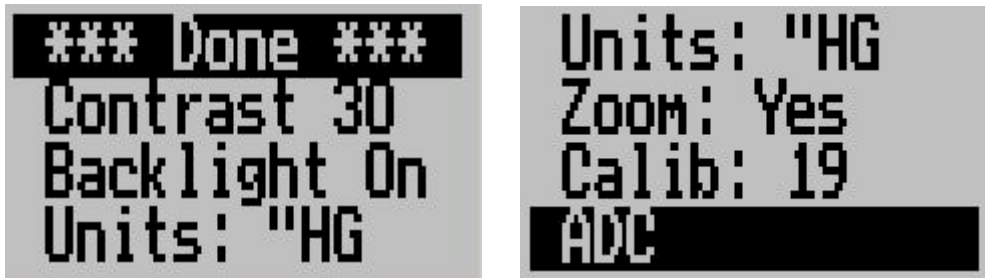

Technical setup functions "Calib" and "ADC":  
(accessible only if you start up the instrument while pressing both "+" and "-" buttons at the same time)

### Contrast ...

This function allows you to change the display contrast to your liking. You can select values from about 20 to 45. (can vary depending on display type).

### Backlight ...

This function allows you to switch the display backlight on or off.

## **Units: ...**

Select the units of measure you prefer for your instrument. You can choose from:

mb - millibars  
bar - bars  
PSI - pounds per square inch  
KGcm2 - kilograms per square centimeter  
"HG - inches of Mercury  
mmHG - millimeters of Mercury  
KPA - kilopascal  
atm - atmospheres (1013.25mB on a standard day)

The highest resolution can be obtained by setting the unit to millibars.

## **Zoom Yes/No**

Select if you would like the bargraph to display from 0 to 2.5 bars (full range of unit) or if you would like to "zoom" the display to show pressures from 0.5 bars to 1.5 bars.

## **Calib...**

This function is for technical personal. It is not used for ordinary operation of the unit. During manufacture of your instrument a calibration value has been entered here that results in optimum accuracy of your instrument. Never change this value unless you have a very accurate reference (accuracy better than 0.1% with a valid and current calibration certificate that has been issued by an accepted standards body.

## **ADC**

This function is for technical personal. It is not used for ordinary operation of the unit.

## Technical specifications:

Display temperature range (operational): -20 to +80 degrees C  
Supply voltage: +8 to +18V. +24/28V with optional pre-regulator.  
Supply current: 25mA/100mA (backlight off/on)  
Pressure range: Absolute, 0.25 bars to 2.5 bars.  
Maximum error over full range: Less than 1% of full scale when operated at calibration temperature.  
Never exceed pressure: 5 bars.

Weight: 90 grams.

### Warranty:

MGL avionics warrants their products for a period of one year from date of purchase against faulty workmanship. Warranty is limited to the replacement of faulty components and includes the cost of labor. Shipping costs are for the account of the purchaser.

### Note for operation on supplies with inductive loads:

Any operation of electronic instrumentation on power supplies that are subject to high voltages caused by operation of inductive loads (starter motors, solenoids, relays) are required to be fitted with suitable protection.

All Smart Singles are guaranteed to withstand temporary over voltage up to 40V without additional protection. We recommend that measures are taken to prevent voltage transients in excess of this limit.

MGL Avionics recommends the fitment of a fuse in line with a 33V transorb (available from MGL Avionics at low cost) to protect electronic instruments, radios and intercom systems. Only one such arrangement is required for a cluster of instruments.

Please note that product warranty excludes damages caused by unprotected, unsuitable or incorrectly wired electrical supplies.

This instrument is not certified by the FAA. Fitting of this instrument to certified aircraft is subject to the rules and conditions pertaining to such in your country. Please check with your local aviation authorities if in doubt.

This instrument is intended for ultralight, microlight, homebuilt and experimental aircraft.

Operation of this instrument is the sole responsibility of the pilot in command (PIC) of the aircraft. This person must be proficient and carry a valid and relevant pilots license. This person has to make him/herself familiar with the operation of this instrument and the effect of any possible failure or malfunction. Under no circumstances does the manufacturer condone usage of this instrument for IFR flights.

## Installing the MAP-1

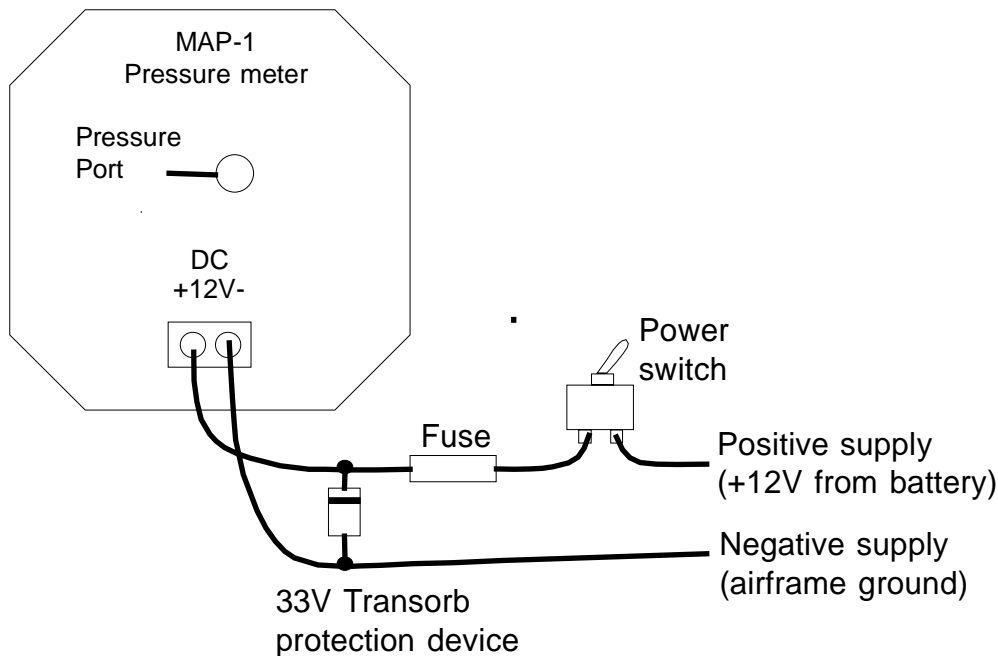

Connect the supply terminals to your aircrafts power supply (you need a dropping resistor or pre-regulator for 24/28V systems).

Install suitable power supply protection if you have a supply that can contain large voltage transients such as can be created by starter motors and solenoids.

Ensure that the supply voltage will not drop below 8V during operation as this may result in incorrect pressure readings.

Standard polyester or silicon hosing with an inside diameter of 3-4mm is suitable as pressure hosing. For high pressure applications the hose should be clamped onto the connector to avoid it slipping off due to expansion of the hose.

For applications where a pressure leak may prove troublesome, such as a typical engine manifold application, a restrictor valve should be inserted into the hose so that only very little gas leakage will be present in a case of failure or if the instrument is removed with the engine running.

For applications where liquid pressure is to be measured, it must be ensured that the liquid is compatible with fluoro-silicon. Fuel is **NOT** compatible.

If in doubt, install an isolation kit. A suitable liquid that can be used to transfer the pressure is ordinary antifreeze as used in cars.

**Pressure sensor damage as a result of applying aggressive or otherwise incompatible gas or liquid to the internals of the pressure sensor are expressly excluded from warranty.**