

Stratomaster Smart Single

GF-1

Tilt compensated dual range aviation G force meter



The GF-1 is a 2.25" instrument that displays the acceleration forces acting on the aircraft. Able to measure out of vertical forces the instrument does not require mounting exactly in the vertical aircraft axis.

Functions in brief:

- a) Typical, accurate range of 20 G (from +10G to -10G).
- b) Records maximum measured forces in permanent memory (both positive and negative)
- c) Two independent cycle counters record number of times a preset force has been exceeded.
- d) Short term memory for maximum force encountered (typically during a flight).
- e) Clearly readable numeric display (10 G range, positive and negative)
- f) Graphic display of force acting on aircraft (range 0-6.5G, positive and negative)

Two axis design of the instrument allows mounting in sloped panels (i.e. panel not exactly vertical).

Quick calibration function for operation at temperature extremes using Earth gravity.

The main display and function buttons

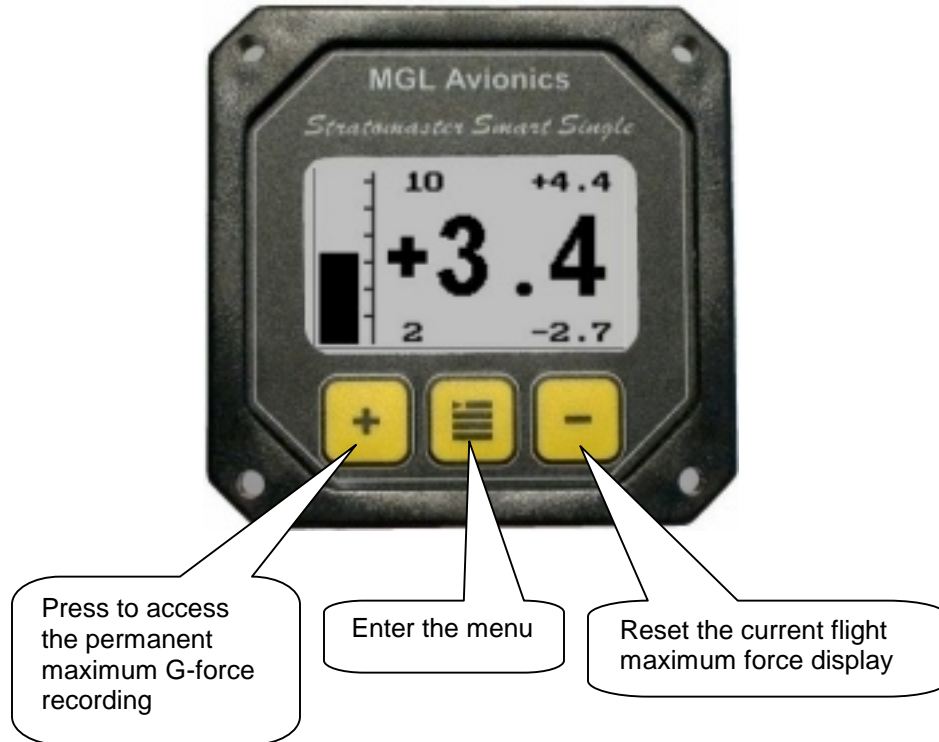
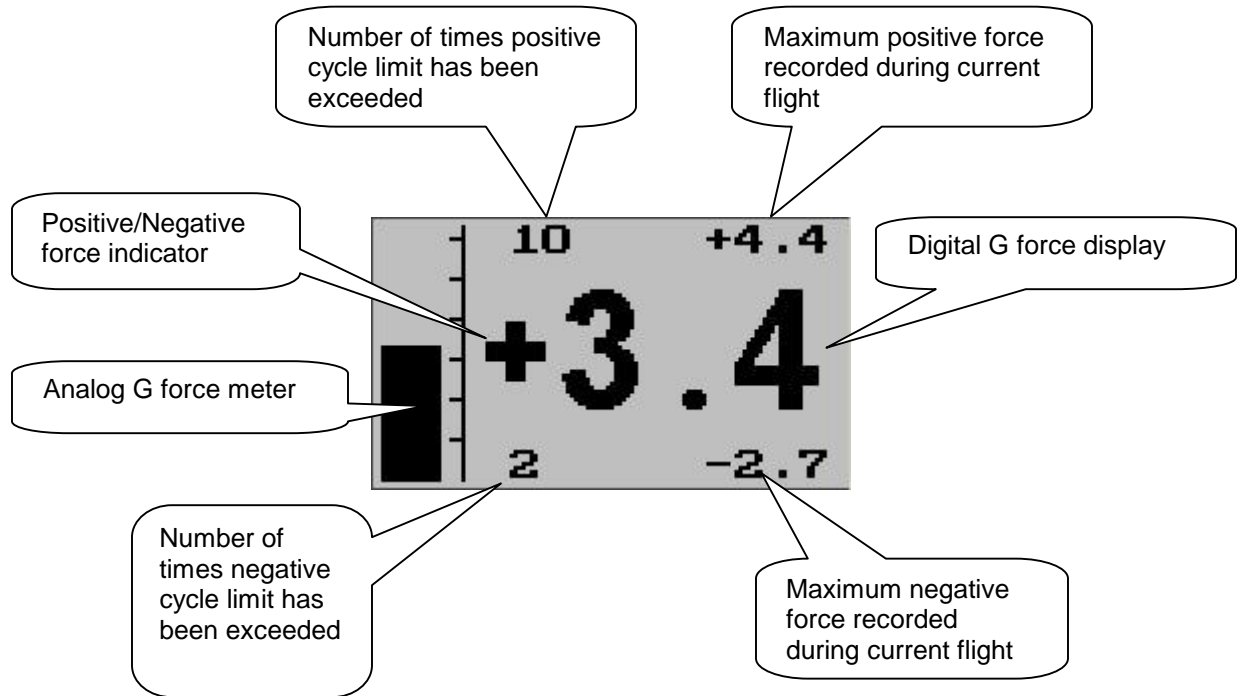

Setting up the GF-1

Press the Menu key to enter the menu. You can move forward and backwards in the menu by using the + and – keys. To change or select a menu item, move the highlight to the desired item and then press the Menu key. To end an edit or function, press the Menu key again.

To exit the menu and continue normal operation, select the *****Done***** function and press the Menu key. Note, all changes you have initiated during your session will only be remembered by the instrument if you exit the menu using the *****Done***** function.

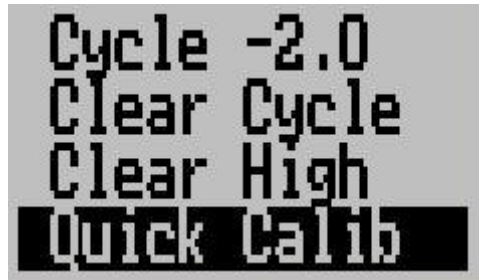

Technical setup functions:

(accessible if you start up the instrument while pressing both “+” and “-“ buttons at the same time)

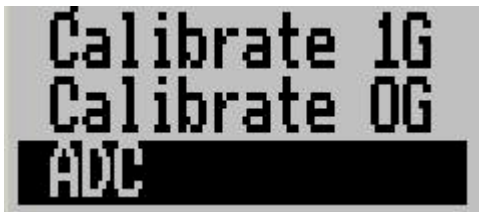

Contrast ...

This function allows you to change the display contrast to your liking. You can select values from about 20 to 45. (can vary depending on display type).

Backlight ...

This function allows you to switch the display backlight on or off.

Cycle +#.

Set the positive G force limit above which the cycle counter should increment.

This would typically be set to the maximum allowable G-force rating of your aircraft (positive G force).

The cycle count is retained if power is removed.

Cycle -#.

Set the negative G force limit above which the cycle counter should increment.

This would typically be set to the maximum allowable G-force rating of your aircraft (negative G force).

The cycle count is retained if power is removed.

Clear Cycle

This clears both positive and negative cycle counter to zero.

Clear High

Clears the permanent recording of highest positive or negative G force measured. This recording is retained if power is removed.

Quick calib

This function allows a quick calibration of the main Z-axis G force sensor. You would typically use this function to set the G force reading to exactly 1.0G (Earths gravity) in cases where the instrument is operated at temperature extremes (very hot or very cold). Temperature has a slight effect on the sensor and this function helps you to maintain best possible measurement accuracy should you operate at temperature extremes.

In order to use this function, the instrument faceplate should be vertical to the Earths surface within 10 degrees.

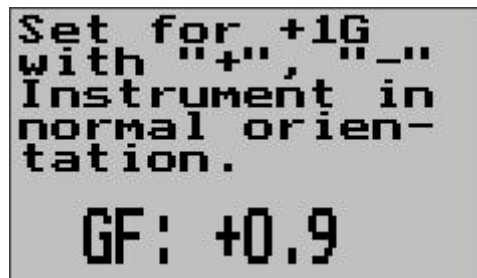

Press "+" to increase the force reading and "-" to decrease the reading. Approximately four key presses are required for 0.1G.

Please ensure that the instrument is in fact exposed to a force of 1G (Earths gravity) in the vertical direction.

Do not use this function in flight. Do not use this function if the instrument is more than 10 degrees from the vertical.

Calibrate 1G

Calibrate 0G

These two functions are available if you are operating the instrument in technical setup mode. You use these functions to calibrate the instrument using the Earth gravity as a reference. Follow these steps when performing a calibration. The order of these steps is important:

Step one:

Place the instrument such that the faceplate is exactly vertical (Normal operating orientation, normal side up as it would be installed in an aircraft).
Press the Calibrate 1G button. You will see a message confirming the action.

Step two:

Place the instrument such that the faceplate is exactly horizontal with the display on top. If placed on a table, you would be looking down onto the display from above.
Press the Calibrate 0G button. You will see a message confirming the action.

Step three:

Place the instrument in the vertical position again (same as in step one). Press the Calibrate 1G again.

You have now calibrated both the horizontal and vertical G force meter using Earth gravity as a reference.

ADC

This function is for technical personal. It is not used for ordinary operation of the unit.

Technical specifications:

Display temperature range (operational): -20 to +80 degrees C
Supply voltage: +8 to +18V. +24/28V with optional pre-regulator.
Supply current: 15mA/90mA (backlight off/on)
G force range: +10 to -10G typical.
G force range: +8 to -8G guaranteed worst case.
Maximum error over full range: Less than 1% of full scale when operated at calibration temperature.
Temperature induced error: 0.002G / degree C or less.

Weight: 90 grams.

Warranty:

MGL avionics warrants their products for a period of one year from date of purchase against faulty workmanship. Warranty is limited to the replacement of faulty components and includes the cost of labor. Shipping costs are for the account of the purchaser.

Note for operation on supplies with inductive loads:

Any operation of electronic instrumentation on power supplies that are subject to high voltages caused by operation of inductive loads (starter motors, solenoids, relays) are required to be fitted with suitable protection.

All Smart Singles are guaranteed to withstand temporary over voltage up to 40V without additional protection. We recommend that measures are taken to prevent voltage transients in excess of this limit.

MGL Avionics recommends the fitment of a fuse in line with a 33V transorb (available from MGL Avionics at low cost) to protect electronic instruments, radios and intercom systems. Only one such arrangement is required for a cluster of instruments.

Please note that product warranty excludes damages caused by unprotected, unsuitable or incorrectly wired electrical supplies.

This instrument is not certified by the FAA. Fitting of this instrument to certified aircraft is subject to the rules and conditions pertaining to such in your country. Please check with your local aviation authorities if in doubt.

This instrument is intended for ultralight, microlight, homebuilt and experimental aircraft.

Operation of this instrument is the sole responsibility of the pilot in command (PIC) of the aircraft. This person must be proficient and carry a valid and relevant pilots license. This person has to make him/herself familiar with the operation of this instrument and the effect of any possible failure or malfunction. Under no circumstances does the manufacturer condone usage of this instrument for IFR flights.

Installing the GF-1

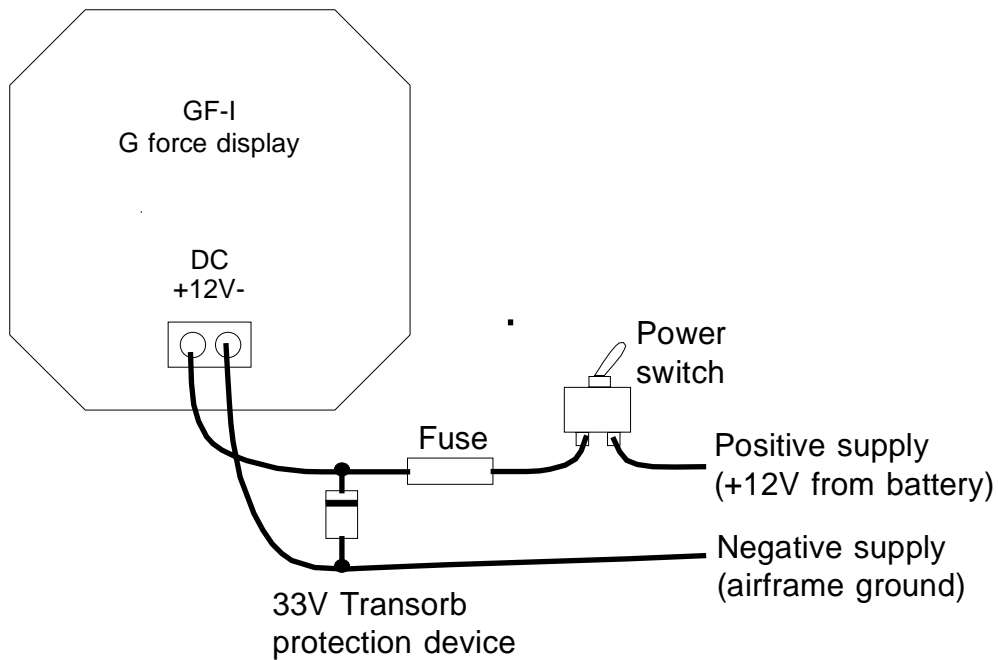

Connect the supply terminals to your aircraft's power supply (you need a dropping resistor or pre-regulator for 24/28V systems).
Install suitable power supply protection if you have a supply that can contain large voltage transients such as can be created by starter motors and solenoids.

Ensure that the supply voltage will not drop below 8V during operation as this may result in incorrect G force readings.

The instrument must be installed exactly horizontal (when viewed from the front) so the force sensor is correctly aligned with the yaw axis of the aircraft (Z axis).
The face plate alignment should be such that it is at less than 20 degree tilt relative to the Z axis.
The instrument is tolerant of sloped aircraft panels but in order to use the quick calibration function the slope relative to the Z axis should not exceed 10 degrees.
More acute slopes can be tolerated but performance should be checked on an individual bases.